



“Fall Into Winter RallySprint”

SCCA RallySprint October 18, 2020



© DAGGERSLADE MEDIA 2019 © DAGGERSLADE MEDIA 2019

Rev O

1. Event Description:

Name: “Fall into Winter RallySprint”

Location: Team O’Neil Rally School, 178 Miller Rd, Dalton, NH

Event Date: Sunday Oct 18, 2020

Sanction: this event is sanctioned by the Sports Car Club of America (SCCA), and hosted by the New England Region (NER).

Insurance: this event is insured through the Sports Car Club of America (SCCA).

2. Purpose: RallySprint is designed to provide affordable seat time to New England’s aspiring rally community. The RallySprint will also give new volunteer workers a chance to learn a position and experienced workers will have an opportunity to try new positions.

3. Supplemental Rules: There is a revision number and date on the cover page. These Supps may be updated prior to the event. The revision number and date will be your verification that you are looking at the most recent edition. Revisions within the document will be in red.

4. Entry: Entry will only be accepted on-line through MotorsportsReg.com. Entry will be considered complete when all required entry forms and materials are submitted and payment in full is received.

4.1 Entry Schedule and fees:

08:00:00 PM	10/17/20	registration opens	See MSR for fee
11:59 PM	10/13/20	Registration closes – contact Kathy Moody if registering after this date.	
		Weekend Membership – required if not an SCCA member	\$15 per person

4.2 Payment: Entry fees will be collected electronically through MotorsportsReg.com . Credit cards for all entries received up to 10/13 will not be charged until 10/13 or later. Entries received on or after 10/14 will be charged on the day of registration or later.

4.3 Refunds: Withdrawals before 10/1 will have no penalty. Refunds after that date are at the discretion of the organizers. Once a team starts the event, there will be no refund.

4.4 SCCA Membership: an SCCA membership affords teams the best entry fee. Either driver or co-driver, or both may be current SCCA members to receive the member pricing.

4.5 Non-SCCA entrants: Non-members (anyone that will be in a competition vehicle) must purchase a weekend membership for \$15 per person. This is in addition to the team entry fee.

4.6 License: Any person driving in the RallySprint must possess a valid driver's license from their home state. No other competition license is required.

4.7 Number of Entrants: The event will be limited to 25 teams. A team consists of a driver and a co-driver. A team is not officially entered until all required entry forms and materials are submitted and payment in full is received. A "wait list" will be maintained in the case of withdrawals, using the registration date and time to set the order.

4.8 Entry Paperwork:

4.8.1 for an entry to be considered complete, the following must be submitted:

- fees: entry, weekend membership – submitted on-line

- required driver, co-driver and crew information –submitted on-line to Kathy Moody email or cell below

- rally vehicle information

4.8.2 Other: drivers may send electronic verification of driver's license, or be prepared to show at registration.

4.8.3 Waivers: all team members and crew must sign the required waivers upon entering the property.

Anyone under the age of 18 must have a minor waiver completed by parent/guardian.

5. Organizing Committee:

Chairman/Registrar:	Kathy Moody	rallykat158@yahoo.com	603-616-1195
Safety Steward:	Scott Beliveau	scbeliveau@gmail.com	603.455.2791
Control Captain:	Chris Regan	chregan@aol.com	203-979-3196
Spectator Captain:	TBD		
Communication Chief:	TBD		
Scrutineer:	tb		
Sweep Captain:	Dan Fouquette		

6. Event Schedule:

Saturday Oct 17, 2020

5:00 PM to 7:00 PM – scrutineering at Walmart in Littleton.

Sunday Feb 9, 2020

7:00 AM – gates at Team O'Neil open, main entrance

7:05 - 8:30 AM - Registration and scrutineering open (early is best!)

9:00 – 9:15 AM – Recce for 1st stage

~9:30 AM 11:15 PM – morning stages

~11:15-11:45 AM – Service/lunch

~11:45-12:15 PM – Recce for 2nd stage

~12:15-1:45 PM - Afternoon stages

~1:45-2:15 PM – Service

~2:15-2:45 PM – Recce for 3rd stage

~2:45-4:15 PM – Recce for 4th stage

~4:45 PM – awards and departure

7. Timing: stage timing will be in minutes and tenths

8. Special Stages: There will be two or three distinct stages, run multiple times. TBD.

9. Competition Classes:

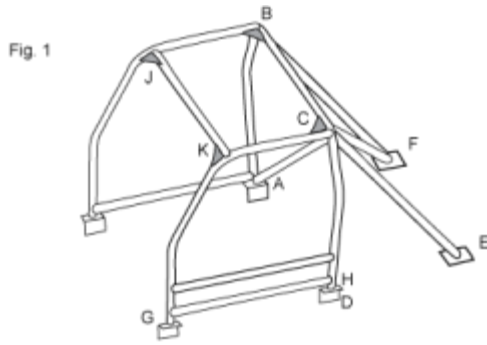

9.1 RallySprint Two-Wheel Drive Under 2.5 Liters (**R2U**) – for front- or rear-wheel drive vehicles with adjusted engine capacity under 2.5 liters, with driver and co-driver.

9.2 RallySprint Two-Wheel Drive Over 2.5 Liters (**R2O**) – for front- or rear-wheel drive vehicles with adjusted engine capacity of 2.5 liters or greater, with driver and co-driver.

9.3 RallySprint Four-Wheel Drive Under 2.5 Liters (**R4U**) – for all- or four-wheel drive vehicles with adjusted engine capacity under 2.5 liters, with driver and co-driver.

9.4 RallySprint Four-Wheel Drive Over 2.5 Liters (**R4O**) -- for all- or four-wheel drive vehicles with adjusted engine capacity of 2.5 liters or greater, with driver and co-driver..

9A. Non-competition classes: The organizers may allow a non-competition “Exhibition Class”. A vehicle running WRC studded tires would be in this

class.

10. Log Books: All cars entering this event must be log booked through Rally America, ARA or NASA. If log booked through another organization, you must contact the Chairman for approval.

10.1 Issuing of Log Book: Due to the compressed schedule for this event, there will be no inspection sessions to issue log books.

11. Required Vehicle Safety Equipment: The following are the minimum safety requirements for the vehicle. It is expected that safety equipment is installed in a manner consistent with manufacturers’ intent.

11.1 Cages: In the instance that a vehicle is older, but still log booked, all cages, regardless of log book must have rear diagonal bars and 2 door bars (configurations may vary). See diagrams below. For questions regarding cages, contact the scrutineer.

LEGEND

A, B, C & D Main Hoop

G, H Side Sill Bar

B, F & C, E Rear Bars

J, K Front Gussets

C, A Diagonal Lateral Bar

B, C Rear Gussets

C, F Diagonal Rear Bar

11.2 Padding: Any portion of the roll cage which could come into contact with the driver or co-driver’s helmet during competition, including all bars in the plane of the roof and forward of the main hoop, shall be covered with energy absorbing material compliant with either the SFI 45.1 specification or FIA Standard 8857-2001 Type A. (**NOTE:** this was an issue with a number of cars at the first event. If you’re not sure how much to cover, covering more is better

than not covering enough. There will not be padding available in the area.

Don't be failed at tech for this!)

- 11.3 Seats:** Driver and co-driver seats shall be firmly mounted to the structure of the vehicle and be installed per the manufacturer's recommendations. Seats must be intended by their manufacturer to be for competition use.
- 11.4 Harnesses:** All vehicles shall be equipped with a five-, six- or seven-point occupant restraint (harness) system meeting the specifications below for both the driver and co-driver. All harness systems shall be capable of releasing with only one latch. These harnesses shall be worn at all times while driving or co-driving. B. Harnesses shall meet the requirements of FIA Standard 8853/98 and/or be SFI 16.1 or SFI 16.5 licensed and shall be labeled accordingly.
- 11.5 Emergency Triangle:** each vehicle will carry 3 emergency triangles.
- 11.6 Tow strap:** each competition vehicle must have an appropriate tow strap in the vehicle.
- 11.7 Tow points:** each competition vehicle must have front and rear tow points.
- 11.8 Fire extinguishers:** One fire extinguisher with a minimum UL rating of 10 BC or two each with a minimum rating of 5 BC must be installed inside the passenger compartment. One fire extinguisher must be located within easy reach of the driver or co-driver when seated. Extinguisher brackets must be metal.
- 12. Scrutineering:** Vehicle and personal safety equipment must be inspected and approved before any vehicle or person may begin competition. A "Tech Form" is included in the Appendix to assist teams be properly prepared.
- 12.1 Saturday night Tech Inspection:** For those arriving in the north country early, there will be a Saturday night Tech inspection. This is not mandatory. Teams passing Tech on Saturday night will not have to be at Tech on Sunday morning. You will be asked to sign a waiver for the weekend and receive your wristband. Please be sure you have it one when entering the gate Sunday a.m. Trying to eliminate the need for everyone to stop at the gate on winter roads.
- Time: 5:00-7:00 PM Saturday, October 17.
- Location: Walmart Parking Lot, Littleton, NH. This is off Exit 42 of I-93. Please send a note to Emmanuel Cecchet or Kathy Moody if you plan to attend Saturday night stating what time you plan to arrive. If an overwhelming number are planning to attend, it will be on a first come first serve basis. Those not through tech by 7:00 PM will have to attend Sunday morning Tech.
- 13. Required Personal Safety Equipment:** The following items are required for all drivers and co-drivers:
- 13.1 Helmets:** All drivers and co-drivers competing must wear helmets that meet one of the following standards:
- 13.1.1 Snell SA2010 or SA2015
 - 13.1.2 Snell SAH2010
 - 13.1.3 SFI Spec 31.1/2010 or newer
 - 13.1.4 FIA 8860-2004
 - 13.1.5 FIA 8860-2010
 - 13.1.6. British Standard 6658-85 Type A/FR, including all amendments will be valid for 10 years from the date of manufacture. If no manufacturing date sticker exists, the helmet will be considered expired.
- 13.2 Head and Neck Restraint Device:** Head and neck restraint systems are required for all competitors. These systems shall be mounted per the manufacturer's recommendations. The head and neck restraint system must meet at least one of the following:
- 13.2.1 Certified to FIA 8858-2002.
 - 13.2.2. Certified to FIA 8858-2010.

13.2.3. SFI 38.1 licensed. SFI 38.1 licensing requires a SFI 38.1 conformance label that is less than five years old.

*See notice regarding counterfeit safety equipment in the appendices.

13.3 Driving suit: All drivers and co-drivers competing must wear driving suits that conform to one of the following standards:

13.3.1 FIA 8856-2000

13.3.2 FIA 1986 or

13.3.3 SFI 3-2A/5.

13.3.4 SFI 3-2A/1 driving suits are also permitted if worn with approved fire resistant underwear.

14. Vehicles:

14.1 Road Legal: Since public roads will be used for the transits, all competition cars must be registered, inspected if necessary, and insured.

14.2 Tires: Appropriate winter tires are required. DOT Studded tires are allowed. They must conform to DOT standards. Homemade studded, bolted, chained, etc, tires not allowed. WRC studded tires not allowed in competition classes.

15. Stage and Transit Notes:

15.1 Jemba style stage notes will be provided for the stages, included in entry fee. They will be prepared by the organizers. These notes are a basis and should not be considered gospel. Teams will be given one recce pass for the purpose of checking and altering the notes as they see fit. Mileages may or may not be included. For those not familiar with Jemba style notes, an internet search of "Jemba stage notes" will return several resources. (P-sport is a good one)

15.2 Transit notes will be in tulip format. Transits will involve driving on public roads. Obey all speed limits.

15.3 Stage and transit notes will be in the same book, the "route book".

15.4 Route Books will be available Friday night at tech and Saturday morning at registration.

15.5 One Route Book will be issued per team.

16. Recce: There will be one pass recce for each stage. Recce may be done in the competition car if necessary. Recce will be parade style, with approximately 30 seconds between cars. Max speed during recce is 30 MPH. This is not a practice run.

17. Car numbers: Each competitor may choose his/her car number. In the case of duplicate numbers, an SCCA membership will provide priority in choice. If neither entrant is an SCCA member, the first entrant registered will have priority.

17.1 Car numbers are not supplied by the event and are the responsibility of the entrants.

17.2 Numbers: Car numbers should be 8" tall and 1.25" brush width minimum.

18. Service:

18.1 General: The service area will be crowded. Please keep your area as compact as possible. CREW MEMBERS ARE LIMITED TO 2 PER TEAM.

18.2: Ground cover: a tarp should be placed down under the vehicle before performing any work.

18.3 Trash: This is carry in – carry out. Do not leave garbage around, including cigarette butts.

18.4 Repairs: Jacking of vehicle:

18.4.1 Jack stands will be used any time more than one wheel is off the ground during service.

18.4.2 A jack stand will be used if only one wheel is off the ground and a crew member is under the car.

18.4.3 Penalty for failing to abide is 5 minutes per offense

18.5 Service vehicles: Only one service vehicle per team will be allowed in the service area. All other vehicles shall be parked in the parking area behind the office/garage.

19. Fueling:

19.1 Teams should bring enough fuel to run the day. There is no fuel availability on the Team O'Neil site and there is not time to leave to get fuel.

19.2 All fueling will take place in the designated fuel depot area (consistent with stage rally rules).

19.2.1 While fueling, a team member must be at the vehicle being fueled with a fire extinguisher.

19.2.2 Penalty for failing to abide is 5 minutes first offense, disqualification upon second offense.

19.2.3 No smoking cigarettes or any other matter in or within 50 feet of the fuel depot.

20. Sweep: There will be two sweep vehicles. In the case of an incident, a sweep vehicle may be dispatched to clear the road. Disabled vehicles will be dealt with as necessary, when time allows.

21. Competitor meeting: All drivers and co-drivers will attend the competitor meeting at 8:30.

22. Observation Controls: "O" Controls may be used, generally to check speed during transit. If you encounter a "STOP" sign board during a transit section, you must stop at the control.

23. Chicanes: There will be chicanes used on the stages. The intent of the chicane is to decrease your speed before a dangerous area of the course, or to keep the overall speed in check. The penalty for hitting chicane features will be 30 seconds per item in the chicane that is displaced. Think of the chicane features as trees....don't hit them.

24. Transits:

24.1 All transits shall be considered Quiet Zones.

24.2 There will be NO SPEEDING. Local authorities will be aware of the event and may have radar in use.

24.3 Penalties

24.3.1 Any team deemed speeding by the O Control worker, in excess of 5 mph above posted limits, will receive a 30 second penalty for each mph beyond 5 above the limit.

24.3.2 Any team issued a citation for speeding will be immediately removed from competition for the remainder of the event. In the case of an infraction on the final transit, a dnf for the event will be issued.

25. Event Decals: There may be event decals supplied at tech. You will be instructed on where to place them. Any decals from rally schools other than Team O'Neil must be removed or covered (The Firm, Dirtfish).

26. Food and beverages:

26.1 Food: Teams should bring their own food for the day. There is no food service on the Team O'Neil site and there is not time to leave to get food. (The chow wagon may be there.) Lunches may be available for purchase through the MotorsportReg site when you register.

26.2 Beverages: Teams should bring their own beverages for the day. There is no consumption of alcoholic beverages before or during the rallysprint.

27. Spectating: This will be a non-spectator event.

28. Lodging: there are multiple options in Littleton, Whitefield areas. No special deals have been made for the event. Search the web.

29. Results: Final results will be posted to the NER.org and teamoneil.com web pages.

30. Awards: Awards will be presented to the top team in each competition class as a minimum.

31. Radio frequencies for event: (tentative) primary: 146.43, no tone backup 146.55, no tone

32. Stage stoppage: If there is a stage stoppage for a red cross situation, road blockage, disabled vehicle, or other reason, the stage will be restarted once the stage has been deemed clear by officials. Vehicles that were stopped or delayed because of an incident may be given a re-run. The vehicle that caused a stoppage will receive a bogey time and no re-run. In the case of a crash, an event official must inspect and clear the vehicle before it may continue competition.

Appendices:

A. Incident procedure:

Appendix A. **ON-STAGE EMERGENCY PROCEDURES**

(this procedure is consistent with Rally America and NASA)

1. If a competition vehicle stops on a stage:
 - a. the team must display the OK sign if they are in fact OK to all passing teams. If a team member is injured and needs medical assistance, the RED CROSS must be displayed.
 - b. the team must immediately put out triangles. Warning triangles are to be placed on the same side of the road that the vehicle is stopped on. It's expected that triangles will be placed within 30 seconds of knowing the vehicle will not continue. One triangle should be placed at or on the stopped vehicle. A second triangle approximately 150 feet back towards the start of the stage, and the third approximately 300 feet back. Take corners or crests into consideration when placing the triangles. The goal of using triangles is to alert approaching teams of danger; place them so they're visible in advance.
 - c. the team must ensure the vehicle does not prevent the passage of other vehicles.
2. A team that is able to continue on the stage after stopping must remove all warning triangles before continuing on the stage.
3. If an incident has occurred and the team is still in the car, triangles are not displayed and no OK/+ sign is displayed, the first team to arrive must STOP. The arriving team should evaluate the situation, and if necessary display the Red Cross and triangles and render assistance to injured competitors.
4. The second team to arrive, seeing a Red Cross, shall stop and get an accurate assessment of the situation and condition of the people, and the location. They should then continue on the stage to the next radio point. This may be a mid-point on the stage, or the stage finish. For this event, on-stage marshals are radio equipped. Information regarding the incident and emergency needs should be given to the radio personnel.
5. Upon notification of the Red Cross situation, the stage will be immediately stopped and medical personnel dispatched from stage start with a radio operator to communicate necessary information.
6. Once the Red Cross is displayed, it must remain displayed. All following competitors must stop and render assistance as needed. Unnecessary teams should then continue to the finish of the stage at transit speed.
7. After the situation has been cleared, the workers at the start control will inform competitors as to how to proceed. At this time, the Red Cross should be removed from the accident scene.
8. The driver of any vehicle involved in a rally related accident resulting in personal injury or property damage must fill-out an Incident Form.

9. If a team has crashed and is not visible from the stage road, or leaves the stage road, and does not require medical assistance, they must still show the OK sign to all passing teams.

Note: An "OK" situation may change to a RED CROSS situation. The above procedures are to be followed beginning with the display of the RED CROSS sign.

COVID-19

Team O has policies in place, READ THEM. <https://www.teamoneil.com/covid-19-safety-guidelines/>

Please provide and wear your own face covering at all times. Exception, Face covering may be removed when in the competition car. Driver and co driver understand that they will not be wearing masks and will be closer than 6 feet when racing. Both understand and accept the risk.

When conversing with any workers, especially timing crews, masks must be worn.

New England Region policies, along with guidelines from SCCA and in cooperation with Team O'Neil Rally School will be following all recommendations to minimize the risk of exposure. The governing issue is if you do not feel comfortable in participating, please do not feel obligated to take unnecessary risk. If there is any question as to how you feel, headache, dry cough, unexplained temperature rise, or other likely symptoms of illness, please do not attend or remove yourself from the area and proximity to others.

1. Some of our members are in high-risk categories. Others may have at-risk family members at home. Do your best to keep them safe.
2. Respect your fellow members. Your opinions about current guidelines are not shared by everyone. Show respect for your friends by your behavior.
3. The virus is not the only threat to our events. Government officials and news organizations have the power to end our season. In addition, our venues can also shut down our events if they observe that we are not behaving appropriately. Just like on a Florida beach, even a photo of people maintaining proper social distancing can look like Lollapalooza. Be cautious when sharing/posting event photos.

Safety First!